



2-3

Congratulations on your decision to purchase a *HeliCommand*.

No other commercially produced system for model helicopters can stabilise the horizontal flight position in addition to the horizontal attitude.

The *HeliCommand* was originally developed from a professional auto-pilot system for commercial helicopters employed in filming and surveying, and is based on several innovative technologies (international patents pending).

The range of applications covers beginners and advanced pilots. However, beginners should be familiar with their model's functions, even if they are not yet able to maintain a stable flight attitude when flying. To all newcomers to the helicopter hobby we recommend to learn more about the basics of helicopter technics to achieve a maximum in performance with the *HeliCommand*.

If you are a beginner, the *HeliCommand* will enable you to hover the helicopter, carry out slow circuits and generally practise more easily. However, one point which should be addressed here is that the pilot must be attentive, and should not let this unique system seduce him into trying manoeuvres which could endanger himself or others.

Also, it is ideal for advanced pilots who are expanding their flying skills and wish to practise flying with reduced stabilisation, as well as pro-standard pilots who wish to concentrate entirely on the important functions of their flight display.

To anyone who categorically shuns all electronic aids for helicopter flying, we have this to say: please be reassured: the *HeliCommand* was not developed with the aim of replacing flight tutors and training procedures; its sole purpose is to help modellers learn to fly safely, and to promote safer flying.

**For quick installation: skip introduction and start with page 14.**

**HeliCommand 3A**

- Stabilises all horizontal control movements: inclination (tilt), speed, position
- Auxiliary „pilot“ channel for adjusting stabilisation effect and switching between horizontal mode and position mode
- Integral heading-lock (AVCS) gyro
- Second auxiliary channel (“AUX channel”) for gyro gain and mode, optionally for automatic trim.
- Internal swashplate mixer
- Can be configured without connection to a PC by simple learning procedure, for up to 3 head servos
- Fail-safe if radio link fails (PPM / FM only): switches to position stabilisation, coll.pitch to ‘hold’.
- Suitable for internal-combustion and electric-powered helicopters
- Can be used indoors and in the open air
- PC adaptor available as accessory, for setup of 4 head servos, optimisation for stabilisation and tail gyro, and additional options like automatic trim, freewheel function for forward flight, etc.

**HeliCommand 3D**

- Includes all the features of the basic “3A” version, plus:
- Horizontal stabilisation for inverted flying
- Expanded set-up facilities via PC adaptor (No. 84942000) (additional Expert settings for optimising the tail gyro, 3D mode and control characteristics).

**HeliCommand RIGID**

- Includes all the features of the HeliCommand 3A and 3D, plus:
- **RIGID** mode for stabilising flybar-less rotor heads (2- or multi-bladed heads), highly effective in preventing ballooning and tuck-under at high speed and in gusty conditions.
- Optimised pirouette stabilisation. No additional setup necessary. (Only units from date code 10.08 on the label!)
- Suppressed oscillation for elevator. Also useable with standard Hiller flybars. (Only units from date code 10.08 on the label!)
- Eliminates the need for aileron (roll-axis) and elevator (pitch-axis) trim functions.
- Expanded mixer options: Virtual swashplate rotation, and sinus-compensation (matches unequal pushrod travels caused by the tilting of servo arms).
- The pilot channel can be used to select: horizontal mode, position mode, **RIGID** mode.
- **RIGID** and horizontal modes even function without visual contact between the optical sensor and the ground, i.e. no opening is required in the helicopter fuselage if you do not need to use position mode.
- Electronic linearisation to compensate for mechanical irregularities (angular offset) when using the H4 swashplate linkage.
- The PC adaptor (No. 84942000) is required for setting Rigid mode. Without the PC adaptor the HeliCommand 3D makes use of the parameters which are pre-set at the factory.

**Index**

<b>LED Display</b>	<b>8</b>	<b>Tips for flying</b>	<b>32</b>
<b>Description of facilities</b>	<b>9</b>	Take-off and landing	32
Pilot channel	10	Hovering	32
Tail rotor gyro	11	Control travels	32
Automatic trim	12	Effect of the opto-sensor	33
Fail-safe	12	In darkness, or when overflying optically smooth surfaces	33
The upgrade versions of <i>HeliCommand</i>	13	Indoor flying	33
<b>Survey - the essentials</b>	<b>14</b>	Checking the contrast	33
<b>Installation</b>	<b>16</b>	<b>Versions and applications</b>	<b>34</b>
Electrical earth	17	<i>HeliCommand 3A</i>	34
On-board location	17	<i>HeliCommand 3D</i> and above	34
Mounting the unit on the tail boom	18	3D manoeuvres	34
Notes regarding internal combustion engines	19	<i>HeliCommand RIGID</i>	34
<b>Setting up</b>	<b>22</b>	<b>Notes</b>	<b>35</b>
Electric-powered helicopter	22	For skilful pilots: differences in handling	35
Factory reset	22	Range of applications	35
Setting up the transmitter	22	<b>Safety measures / We recommend</b>	<b>36</b>
Calibrating (learning) the transmitter neutral points	22	<b>Liability exclusion / Guarantee</b>	<b>37</b>
Configuring the <i>HeliCommand</i>	23	<b>Fault-finding</b>	<b>38</b>
Setting up the <i>HeliCommand RIGID</i>	26	<b>Specification / Set contents</b>	<b>40</b>
<b>First flight</b>	<b>28</b>	<b>Accessories / Service / Imprint</b>	<b>41</b>
Test-flying	28		
Internal-combustion helicopters: vibration test	28		
Trimming	30		

### LED Display

- Power up:** Power up phase, please don't move for 10 s;  
 ● ● ● still no output of servo-signals.
- Normal operation:** Color indicates the pilot channel position
- Off / conventional controls (glowing red)
  - Horizontal mode (glowing orange-yellow)
  - Position mode (glowing green)
- ■ ■ ■ ■ Flickering green: not enough contrast, only horizontal mode but no position mode.  
*For checking: switch to green mode and hold helicopter in different distances above ground by hand.*
- ● ● ● ● Trim button is pressed, and connect to AUX-Kanal and assigned (via PC-adaptor)
- Setup:**
- Complete neutral positions learning (then power off)
  - Setup process (step number = count of flashing)

- Fault at selftest** (LED flashes red) No output of servo-signals
- (1x) No R/C-receiving (during selftest)
  - (2x) Battery < 4V power up (Do not use for charge monitoring!)
  - (3x) Movement during power up phase, repeat power up (if necessary wait for temperature change to settle)
  - (4x) Instruments fault or too extreme temperature
  - (5x) Auto trim value at the limit (must be cleared and adjusted mechanically)
  - (6x) (reserved)
  - (7x) Unacceptable center divergence at automatic learning process; at least one channel out of center?
  - (8x) No R/C receiving at automatic learning process

### Description of facilities

Basically, all versions (3A, 3D, Rigid) offers the following modes of operation:  
 LED red = stabilising functions switched off (= conventional)  
 LED yellow = horizontal mode  
 LED green = position mode

Horizontal mode („yellow“): moves the helicopter to the horizontal attitude if you release the aileron (roll-axis) and elevator (pitch-axis) controls. This works totally independently of the optical quality of the ground surface. For indoor flying you should select this mode; if you do not wish to, please read the notes on page 29.

Position mode („green“): in this mode the unit stabilises the model's position as well as its horizontal attitude. This is the most powerful stabilisation, and is ideal for "automatic" hovering and slow circuits. It works most effectively at heights of about 0.5 to 2 metres above a natural surface (grass, gravel etc.). If you release the aileron and elevator controls, the system actively brakes the helicopter until it is stationary; all the pilot has to control is the collective pitch / throttle function. If the model exhibits any slow drift at the hover, this can very easily be corrected manually. For slow circuits close to the ground, you can set a forward speed by keeping a slight constant push on the elevator stick, then direct the model using the tail rotor stick (just like steering a car).

For higher speed and for flying at heights above about 5 m, this mode would tend to be a nuisance because of its corrective actions; in this case you should switch to horizontal mode („yellow“).

The configuration for the above-described functions is possible without PC, unless four head-servos are used.

**RIGID** mode: this is a fourth mode of operation only available with the *HeliCommand RIGID*: it is designed for flybar-less rotor heads, stabilising and maintaining the helicopter's attitude (see page 5).

**Rigid** mode can be combined to working parallel with the three modes described above. These options are explained on page 26.

In addition to the previously described stabilising functions, all *HeliCommand* versions offer the following supplementary functions:  
**swashplate mixer, tail rotor gyro and automatic trim.**

## 10-11

### Pilot channel

We recommend that you use this auxiliary channel as it enables you to switch between the three modes, and also to set the desired stabilisation power. It is advisable to use a slider or a three-position switch with selectable output values for the pilot channel.

If the pilot channel is not connected to the receiver, a pre-set value applies which is: position mode with a setting of +70%; this is a suitable setting for many models, and can be changed to any value you like using the PC adaptor.

slider position signal %	LED-color	stabiliser-effect	sensitivity
+ 100 % (Futaba = -100)		<b>POSITION MODE</b> unsuitable for flying and inverted flying!	100
0 % 1,5ms		<b>OFF</b> (normal hand control)	50
- 100 % (Futaba = +100)		<b>HORIZONTAL MODE</b> <i>HeliCommand 3D</i> and <i>RIGID</i> : Also for inverted flying	100

Slider more towards the center reduces the sensor gain and slows down the corrections.

Additionally, the auto pilot can be overridden by smaller stick deflections.

You may of course exchange up with down side, by reversing transmitter setting or slider mounting.

### Tail rotor gyro

The *HeliCommand* features an integral gyro which can be operated in either normal or heading-lock mode (with AVCS). Use high-speed digital servos for best performance. Not suitable for "narrow-pulse"-servos.

A second auxiliary channel ("AUX channel") is used to adjust the gain setting, and to switch between heading-lock and normal mode.

If the AUX channel is not connected to the receiver, the internal default setting applies. This is heading hold mode set to about +65%; it can be adjusted using the PC adaptor.

Further adjustments can be made using the PC adaptor, e.g. travel limiting and collective pitch > tail rotor mixing; the latter is mixed in after the gyro, and therefore also works in heading lock mode.

The versions *3D* and *Rigid* provide additional „expert“ adjustments e.g. delay and "hold"- range".

If you do not wish to use the integral gyro, an external gyro can be connected directly to the receiver. In this case please note the following points:

1. Yaw turn rates above 400° / sec. are not allowed, since they might seriously disturb the stabilisation system.
2. If you subsequently decide to use the internal gyro, you must first erase any internal auto-trim values, and check the sensor direction of the gyro.

## Automatic trim

This is recommended, but is not absolutely essential. Auto-trim works independently of the auto-pilot, and makes life considerably easier for beginner and pro-pilot alike. To use it, your transmitter needs a momentary (self-centring) button or a toggle switch, assigned to an auxiliary channel. Many transmitters feature a Trainer switch which can be re-programmed for this purpose. The AUX channel has to be configured as the trim function using a PC. When the model is flying, a brief button-press is sufficient to generate the trims automatically for aileron, elevator and rudder (tail rotor). The settings are stored in the unit, but can be revised at any time. The automatic trim function requires around eight seconds of steady hovering in order to record the correct trim values; they can then be called up immediately by pressing the trim button. Automatic trim can also improve the performance of the integral tail rotor gyro if the neutral pitch angle of the tail rotor blades is not adjusted properly. Independently of this, the tail gyro has once to be adjusted manually, see page 30!

To activate auto-trim, the AUX channel has to be configured as the trim input using the PC adaptor. The trim is then triggered by switching the AUX signal to +100% (> approx. 60%) (note that in Futaba transmitters „-100%“ means „+ 100%“ and vice versa).

The LED flickers red to indicate while auto-trim is being sent.

The AUX-channel, if assigned to auto trim, will still switch off the heading-hold-mode by a negative signal -100% (< -60%), but Gyro gain (sensitivity) has to be set by PC only. Thus a gyro-mode-switch can be combined into the same channel (e.g. by flight state programming). If you wish heading-hold, then the AUX channel must not send a negative signal; the trim switch should only switch between zero and +100% (Futaba = -100%). Note that the trim channel must not be assigned to any other transmitter control actions which you may have programmed, as you might then trigger auto-trim accidentally. The trim switch should only be operated with the model in flight (unlike the SET-button).

For erasing the internal auto-trim values:

call up the set-up mode (page 23), and then switch on again.

## Fail-safe

If you are using an FM / PPM system without own failsafe function, the auto-pilot immediately responds to a radio link failure by carrying out the following actions: aileron, elevator, tail rotor to neutral, collective pitch to the last received position, stabilisation to position mode, set to 65%. Receivers with integral failsafe function should explicitly be programmed to the mentioned positions. For optimum security we recommend the use of PCM systems.

## The upgrade versions of *HeliCommand*

### *HeliCommand 3D*

This version stabilises both the normal flight attitude and the inverted flight attitude. (In inverted flight this is limited to horizontal stabilisation („yellow“, because position holding („green“) requires a visual link between the CCD sensor and the ground.

Even so, this is sufficient to make inverted hovering and aerobatics very much easier.) Adjustments are done the same way as with the *HeliCommand 3A*. More adjustments are optionally available via PC.

The system does include optical interference suppression for situations where the CCD sensor is directed towards the sky, but for safety's sake the stabilisation mode should always be switched from „green“ to „yellow“ before you start a session of aerobatics or inverted flight.

This is particularly important for indoor flying, but also for high-speed circuits and flying at fairly high altitudes.

Additional important notes: see “Tips on flying”, page 32

### *HeliCommand RIGID*

If your rotor head has no flybar, you must use the *HeliCommand RIGID*, and you must activate **RIGID** mode.

If not, the stabilisation may not work properly due to the occurring turn rates!

All the **RIGID**-Mode set-up functions can be accessed using the PC adaptor; they are explained in detail in the *HeliCommand* set-up software; once you have selected *HeliCommand RIGID* as the device type. If you do not change the set-up using the PC adaptor, the *HeliCommand RIGID* behaves exactly like the *HeliCommand 3D* (page 27).

### *HeliCommand Profi*

The professional version of the *HeliCommand* is designed for particularly valuable model helicopters as well as for industrial helicopters and commercial applications such as filming, still photography, surveying etc. It is designed for maximum possible precision, and features important supplementary airborne instruments and other features including auxiliary optics for redundant drift detection, greater flight altitudes and altitude stabilisation.

For more information please visit: [www.helicommand.com](http://www.helicommand.com)

## Survey - the essentials

The unit is as simple as we could make it in terms of setting-up and flying. However, if you are a beginner to helicopters it is really essential to ask a friend with experience of flying these machines to help you at the initial test-flying stage, as the functions of a helicopter are very complex.

This double page and all the points marked with an exclamation mark  are particularly important, and should be read carefully even by pro-standard pilots.

### Installation

- Mount only by using the supplied self-adhesive soft foam stripes, strictly according to the instructions (pages 16-18).
- An electrical connection must be created as an earth between the tail boom, the motor crankcase and the helicopter chassis.
- The higher in the model the unit is installed, the smoother the stabilisation in position mode when close to the ground.
- Please ensure that the unit is set vertically, securely fixed in the model, and with an absolutely unobstructed view between the sensor and the ground.
- Important notes for internal-combustion helicopters and comprehensive installation tips: see page 19.

### Transmitter

All the mixer functions for elevator, aileron and tail rotor must be disabled: always set single-servo mode (H1 or CCPM), as the *HeliCommand* is designed to use its own internal mixer exclusively.

### Configuration

The unit must be configured in order to match it to the model and the RC system; this only needs to be carried out once (page 23).

If the standard default settings suit your model and RC system (page 22) this setup can be omitted.



Before the first flight with the system it is essential to check the controls and sensor directions on all three axes! (page 28)

### Switching on

When the *HeliCommand* is switched on, it carries out a self-test (LED flashes 8 x).

During this period the helicopter must be standing horizontal and must be left untouched.

LED flashes red continuously: error message (page 8)

### Take-off

Don't take the model off before the servos are responding to the controls!

It is important to check the controls because the throttle servo or speed controller would respond to the transmitter even if all the other servos were not yet receiving a signal; this might be because the self-test is still running, or because an error has been detected.

### Flying

Please observe the safety measures (page 36) at all times.

In particular, never take your eyes off the helicopter in the air even when position mode is switched on, as occasional drift or interference influences may occur at any time without warning.

- Indoor flying: please be sure to read the notes on page 33
- Do not fly inverted or attempt aerobatics (3D) with the 3A version; see page 34
- Models without a flybar can only be stabilised using the **RIGID** version, and only then if **RIGID** mode is activated; see page 34
- Even though the system incorporates integral fail-safe and stabilisation circuits, it is not capable of avoiding all crashes caused by radio interference, other transmitters etc. We recommend that you use a PCM system, and check the aerial deployment in the model very carefully.
- Severe stress, vibration and ageing will eventually take their toll on system accuracy, and may require a readjustment of the internal calibrations and temperature compensation values if good precision is to be maintained. This work can be carried out by any Robbe Service Centre.

## Installation

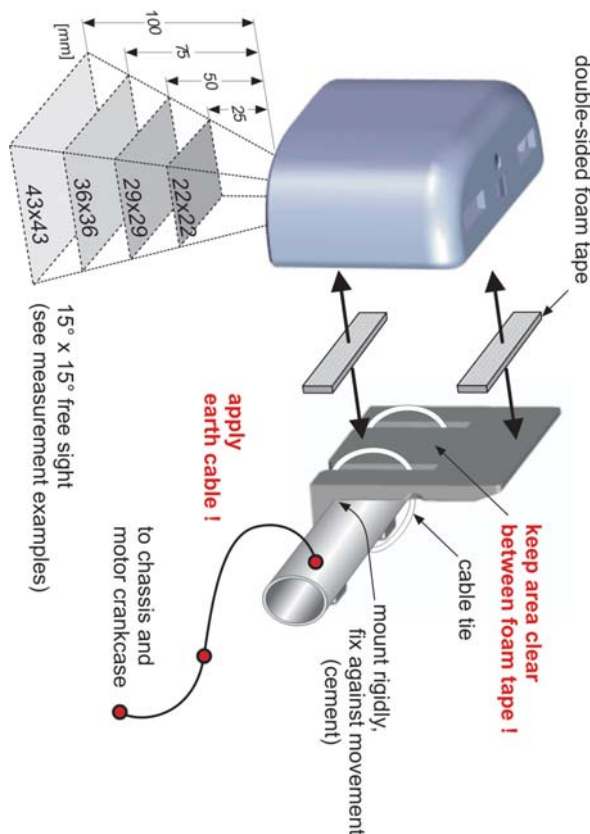
**Electrical earth** !

An electrical connection must be created as an earth between the tail boom, the motor crankcase and the helicopter chassis. Note that carbon is a conductive material! Belt drives inside the tail boom are particularly dangerous, as they act as a high voltage generator. Cables running along the tail boom may conduct sparks to receiver and servos.

**On-board location** !

The mounting surface should be solid and should not "give", as this could generate resonance effects.

For Position mode: the higher the installation location in the model, the smoother the stabilisation effect in position mode at low altitude, and the larger the possible gain setting you can safely use. In many models a suitable location is one side of the tail rotor servo, or - using the mounting bracket supplied - the tail boom, the tail rotor servo, the chassis or the fuselage nose.

**Installed attitude** !

Vertical, with optical sensor facing down.  
Any of the four possible directions can be used.

**Unobstructed view between the sensor and the ground**

The cross-section of the vision cone is square, with an open angle of 15° x 15°. For this reason you must arrange an unobstructed square vertically below the sensor, with at least the side length of (safety tolerance included)

$S = \text{window size (15mm)} + [0,28 * \text{distance from window}]$   
(see drawing on the left side) !

It is important that neither the aerial wire nor anything else can get in the way of the vision beam!

**Installation in an enclosed fuselage**

Cut an opening in the fuselage (see above for size); alternatively do not cut a hole (no sensor view), and manage without position mode. In this case cover the sensor window with dark adhesive tape.

If you do this, you can only exploit horizontal mode, and not position mode.

## 18-19

**Mounting the unit on the tail rotor servo**

In case of a vertical mounted tail servo, you can stick the HeliCommand to the tail rotor servo case (with foam tape) without using the mounting bracket. Alternatively, for maximum distance to ground and especially with small models, it makes sense to install the unit as high as possible. This means: as close as possible under the flybar, with a safety margin for maximum flybar travel.

The mounting bracket supplied can often be fixed to the top of the tail rotor servo or some other support. Do not use foam under the bracket, fix the bracket rigidly.

**Mounting the unit on the tail boom**

Fix the supplied mounting bracket to the tail boom using a cable tie, pulling it really tight. The HeliCommand can then be fixed to the bracket by applying two strips of double-sided foam tape to the back of the unit. Once test-flying is complete, secure it against rotation relative to the boom, using UHU-hart or cyano-acrylate glue. Double-sided foam tape is too soft for this purpose.

**Protect from vibration** !

Please take particular care to protect the unit from vibration! Always use the supplied special soft self-adhesive foam tape, and only two narrow strips right along the top and bottom edges of the back panel. This means that the mounting surface must be at least as tall as the HeliCommand itself.

! Do not apply anything which might constrain the special damping features of the supplied foam tape.

Remove all traces of oil residue before sticking the unit in place, in order to ensure that the HeliCommand cannot shift or come loose, as this could cause the model to take up an inclined attitude in stabilisation mode, rendering it uncontrollable.

(If you fear that the self-adhesive foam tape could be coming loose, we recommend to wrap a thin rubber band around the HeliCommand. The band must be soft enough so that it will not press the foam strips essentially thinner than they are).

**Horizontal attitude**

Set the unit as close to vertical as possible, i.e. parallel to the main rotor shaft! The electronic compensation means that an angled installation would only be noticeable when the pilot gives a tail rotor command.

Miniature helicopters with particularly large blade pitch angles invariably hover with a more pronounced tilt; this is necessary to counter-act for the greater tail rotor thrust. You can compensate for this tilt using the PC adaptor, or see the page 38: „fault-finding“.

**Notes regarding internal combustion engines** !

- The unit must be installed as far from the exhaust as possible.
- Effective vibration protection is very important, as invisible vibration from the engine can be a particular problem. If you can feel the HeliCommand unit vibrating when the engine is running, even though it is installed as directed, we recommend additional vibration damping measures.  
The safest option is a metal plate (3 mm aluminium or 1.5 mm steel) which is first stuck to the HeliCommand; the foam strips are then applied between this plate and the mounting surface. Additionally secure the HeliCommand with thin soft rubber band.  
Alternatively you could consider installing the unit in a different location, where vibration is not so severe.
- Avoid running the motor unnecessarily rich, to avoid clouds of smoke confusing the sensor.
- To prevent soiling we recommend that you install a protective tube, or (better) a cubic box under the sensor. Its internal dimensions must take the vision cone into account. Be sure to clean the window regularly right to the edges.

## Connections

All modern radio control systems include helicopter mixers which ensure that the servos move as required, for example, the superimposed servo movements required for a three-point swashplate linkage. However, when the *HeliCommand* is used, the mixing must be carried out using the unit's integral mixer. For this reason please select an unmixed helicopter program ("H1" / CCPM / single servo) at your transmitter, so that only one servo moves when you move any transmitter stick in any single plane. Once this is the case, you can start connecting the system. If you are not sure how to set up the radio control system, please ask the transmitter manufacturer. Alternatively - if a throttle curve is not required - select a standard (base) program instead of a helicopter program. This also guarantees that the signals from the auxiliary channel sliders and switches are also transferred without any mixing. Attention: if using an H4 swashplate linkage, the PC adaptor is necessary.

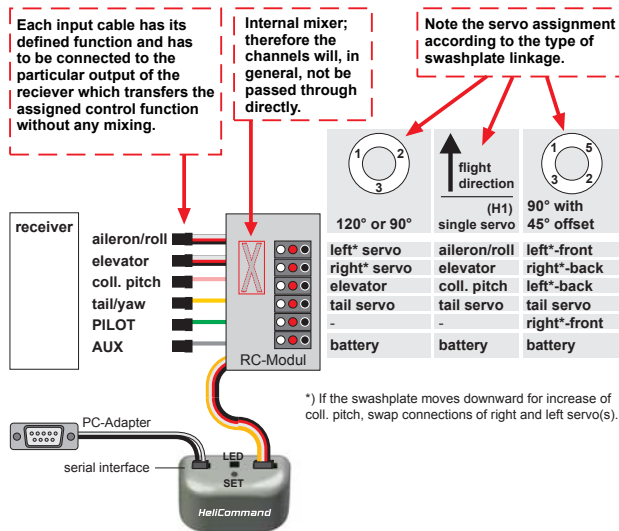

- The RC module (with cable distributor) supplied in the set must be connected between the receiver and the servos. It can be attached to the receiver using Velcro or double-sided tape.
- (\*) If the swashplate moves downward for increase of coll. pitch, swap the connections of right and left servo(s).
- You must connect at least the aileron, elevator and collective pitch inputs to the receiver.
- The PILOT and AUX connections are optional. Connect these cables to the receiver output sockets to which the associated transmitter controls (sliders or switches) of your RC system are assigned.
- The *HeliCommand* switches itself on when you switch the receiver on. Connect the receiver battery directly to the RC module instead to the receiver (shortest way for servo currents). In case of BEC supply and high servo currents (e.g. with four digital head servos), we recommend to install an additional power cable from the BEC controller directly to the battery socket of the *HeliCommand*. This cable must not contain a (third) signal wire (or cut that wire).
- Unused input cables can be stowed away by turning them through 180° and connecting them to unused sockets on the receiver or the RC module.
- Cover the vacant socket on the *HeliCommand* with adhesive tape to prevent soiling.
- LED and sockets are internally supported softly and must remain free to move in all directions.
- For extended cable length to the main unit, a ferrite ring is required with at least 3 loops close to the processor board side.

## 22-23

## Setting up

When you have installed the system, or made changes at the transmitter, the *HeliCommand* must be set up (only once) to match the model and transmitter, unless you wish to leave everything at the default settings: e.g. Robbe-Futaba transmitter, Spirit LI model helicopter, or a similar type with the same servo directions and with round side of *HeliCommand* facing to the right.

In any case it is essential to check the sensors and the control directions before flying the model (page 28)!

Optional set-up facilities:

- Using the SET button: as described below, for (almost) all swashplate types up to 3 servos.
- Using the PC adaptor: in this case only steps A to D-step1 are required. Then see the set-up software, begin with reading the data from *HeliCommand*. PC is necessary if you are using an H4 swashplate linkage, *HeliCommand Rigid* and/or virtual swashplate rotation.

### Electric-powered helicopter

Be sure to disconnect the drive motor or motors to prevent them bursting into life accidentally; alternatively connect the receiver to a separate battery!

#### A) Factory reset

This resets the unit to the factory default state. It erases all settings. Necessary only if settings had been changed which are only accessible with the PC adaptor. Switch on the *HeliCommand* with the SET button pressed in, then release and press again for at least five seconds until the LED flashes red-green alternating.

#### B) Setting up the transmitter

All swashplate mixer functions must be switched off permanently. Set the elevator and aileron travels at the transmitter to around 100%. Values for Expo can be set. Transmitters with 1.6 ms norm (Multiplex) must be set to the UNI mode (1.5 ms). If the integral heading-hold gyro is used, all tail rotor mixers must be switched off at the transmitter.

#### C) Calibrating (learning) the transmitter neutral points

- Set the transmitter sticks to neutral, collective pitch to minimum, trims to neutral, or - if you have already test-flown the helicopter using the *HeliCommand* and only small trim values are set - leave the trims where set.
- Hold the SET button pressed for one second until the LED glows green, then release again - Job done. (If the LED does not become green: p. 8)

The *HeliCommand* now "knows" the signals which correspond to the "neutral and stationary" command. The calibration can easily be repeated. Recommended each time the transmitter trims have been moved substantially. Otherwise, leave the trims alone once the unit has "learned" the settings. Servo positions are not influenced by the calibration process (only if you make changes to the unit's internal mixer, servo centre might be affected and need new trim). When using the auto-trim option, the elevator and aileron trims can remain unchanged all the time.

#### D) Configuring the *HeliCommand*

The helicopter's mechanical systems (neutral position of swashplate and tail rotor) must be adjusted at least approximately (fine trim follows afterwards). The calibration process requires: all servos correctly connected, any swashplate mixer at the transmitter completely disabled and the stick functions correctly assigned by plugging the input cables to the corresponding receiver outputs. If in doubt, connect one servo directly to receiver in order to insure that each channel only responds to one stick function and to find the proper channel of each function. Now simply run through the following steps:

#### Calling up the set-up mode

Calibrate the transmitter neutral setting (see above „C“), but holding the SET button pressed in for at least three seconds until the green LED starts flashing. This simultaneously erases the internal auto-trim values. The servos will now not run, or will run differently to normal, according to the stage of the set-up procedure.

#### Settings for each step (1-5)

Setting is carried out using the stick actions described below. A long press on the SET button (until the LED starts flashing again) stores the settings and automatically leads you to the next step.

#### Changing the set-up step

The current step (1 - 5) is indicated by the number of flashes. When you call up setup mode, step 1 appears first. Press the SET button briefly to move on to the next step without changing the setting; this also can take you back from step 5 to step 1. This way you can select and change any parameter any time. However, for the initial set-up procedure please run through all the steps, as described below.

#### Closing set-up mode

This is possible at any time simply by switching the system off.

## The set-up steps

### 1) Learning the stick direction

- In set-up mode the LED will flash green at regular intervals. Check that any electric power system is disconnected.
- Hold SET button pressed in, and move the transmitter controls to their full travel (in any order) with the button pressed in:  
Right-aileron, elevator forward (push), right yaw (tail rotor stick), then neutral again; collective pitch maximum and leave it there. Now release the button. From this point on you must not change the direction of any channel at the transmitter (apart from deliberately reversing collective pitch).

### 2) Servo directions "collective pitch" (and recognizing linkage type)

The LED must flash twice (press SET button briefly if necessary to move on to the appropriate step). **Servos will not respond to aileron!** You can now select the right one from the ten possible coll.pitch options, working forward or back by moving the aileron stick to either side. The collective pitch stick should evenly move the swashplate up and down, without tilting. Store the correct setting with a long press on the SET button until LED flashes again.

### 3) Servo directions „elevator“ (and „aileron“)

The LED must flash three times (press SET button briefly if necessary). Now select the right elevator function from the two or eight possible options, working forward or back by moving the aileron stick to either side. The elevator stick should tilt the swashplate evenly, without changing its height. For single servo linkage type only: choose amongst the 2 possibilities using right roll stick movements only, and if additionally the aileron direction has to be changed, hold the aileron stick to the left for a longer time (1.5 s) and test with left stick movements (available only with *HeliCommand* versions carrying a date code on the left side of label). With any other linkage type, the direction of aileron travel should automatically be correct after storing; otherwise simply swap the right with left servo at their connections on the RC module. Store the setting with a long press on the SET button until LED flashes again. Now all three directions of swashplate travel should be correct. If the swashplate is not level, adjust the mechanical linkages at this point.

### 4) Servo direction, "tail rotor"

(If external gyro is used, skip this step.) The LED must flash four times (press SET button briefly if necessary). Select correct direction of tail rotor servo by moving the aileron stick to either side: with tail rotor stick to the right, the nose should move to the right, the tail rotor must "blow" to the right. You can now adjust the tail rotor neutral point, since heading hold is disabled in Step 4. Check the setting, and store it with a long press on the SET button until LED flashes again.

### 5a) Installed position (sensor direction)

The LED must flash five times (press SET button briefly if necessary). The *HeliCommand* now needs to know its installed orientation, i.e. whether the round side of its housing is facing right, left, forward or back. Program this by moving the aileron or elevator stick towards the appropriate side of the swashplate.

### 5b) Direction of main rotor rotation

In step 5 move tail rotor stick in same direction as the direction of rotation of the main rotor (viewed from above), and store it with a long press on the SET button until LED flashes again.

## Concluding the setup

Switch on again (keep unit still during power up) and check the controls. Set any travel reductions at the transmitter to prevent mechanical fouling, and set the correct collective pitch range (because travels may now be different to those set when you were using the transmitter's mixer). Any major travel reductions should be set in the *HeliCommand* using the PC adaptor. The swashplate should now be exactly horizontal; if not, adjust it at this stage. Coarse adjustment: there should be a point in the middle of the collective pitch range where all the servo output arms are at neutral simultaneously. If not, unscrew the output arms and replace them in the correct position. For fine-tuning: adjust the pushrods and / or use the transmitter trims and then use the SET button so that the *HeliCommand* "learns" them again.

For transmitters featuring multiple flight modes (phases): It is important to have identical trim values for all flight modes while the *HeliCommand* is activated!

## Setting up the HeliCommand RIGID

Before using the system in a flybar-less helicopter please note that it is essential to activate **RIGID** mode (using the PC).

The attitude-maintenance stabilisation ("head gyro") maintains an angle of inclination once set, and prevents the model from ballooning up into wind - to the extent of the helicopter's control system's power to provide the corrective action. You can observe this function at the swashplate, as it will remain in the inclined attitude you have set.

Depending on the setting, some care is required before take-off to ensure that the swashplate is not accidentally set at too great an angle (through slow drift or accidental movement), and that the RIGID gain is not set too high. Unlike usual practice with tail gyros, the gain setting does not need to be set hard up to the limit of oscillation!

The *HeliCommand* must only be used to control flybar-less helicopters with the **Rigid** mode switched on!! Otherwise there is a risk of generating excessive aileron / elevator rates; this could overload the sensors internally, and this in turn could have a serious adverse effect on the horizontal mode and the position mode!

Scale models often have their swashplate travels mechanically reduced to about half of „conventional“ aileron and elevator travels. When employing the *HeliCommand*, we recommend to undo the reduction, i.e. increase the mechanical throw in order to achieve optimum stability.

**Rigid** stabilisation has to be activated using the PC. Please check [www.helicommand.com](http://www.helicommand.com) for the latest software update, after you have done the basic installation.

**Rigid**-stabilisation includes the following options: (also see PC software for further details)

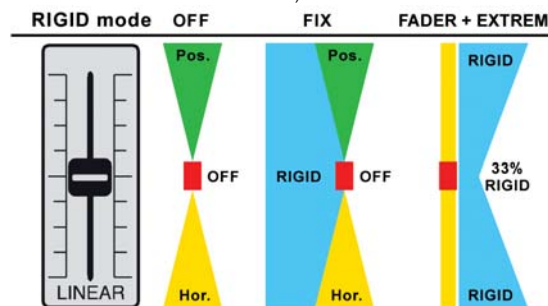

### [OFF] mode

Equals the *HeliCommand* 3D. Not suitable for flybar-less helicopters!

### [FIX] mode

Activates the **RIGID** function permanently, in addition to Hor.- and Pos.-mode as defined by Pilot channel. In this mode, the sensitivity / gain can not be reduced during flight using the Pilot channel. It remains as defined by PC software in the „Rigid“ menu. Excessive gain can cause dangerous oscillating movements. For finding the best gain setting we recommend to use the modes [FADER] or [EXTREME].

### [FADER] (scale) and [EXTREM] (aerobatics) mode

Suitable for finding the optimum rigid gain setting and for more agile flying. Disables Hor.- and Pos.-mode (conventional control). With pilot channel at travel end (100% in either direction) gain becomes as defined at the PC for aileron and elevator - same as the mode [FIX] does. Pilot signal towards the centre will reduce these gains proportionally; at neutral remain 33% of the PC gain settings, as a minimum. A good gain is about 30% below the onset of oscillation in speedy flight. If later you switch to [FIX] mode, you must reduce the gain setting via PC by the same proportion as found on the pilot slider. (E.g. Rigid-sens-gain (roll) = 7, Slider = 70% => new Rigid gain = 7 x 70% = 4.9, i.e. set to 5).

## First flight

### ! Before first flight check the controls incl. allsensor directions

- Neutral setting, directional sense of all stick and servo movements.
- Pilot channel: check by LED (see pages 10 and 27).
- All three sensor directions. Any sensor working in the wrong direction would cause the helicopter to crash. Set the stabilisation to "yellow" mode and briefly move the model to and fro by hand, working around all three primary axes: tilt to the side, tilt forward and rotate. At each movement the appropriate servos must respond with the opposite action: the swashplate should try to remain horizontal, the front faces of the tail rotor blades should move in the opposite direction to the tail swing direction.
- Carry out a range check with the transmitter aerial collapsed.

### Test-flying

If you are a beginner, we recommend that you ask a modelling friend with experience of helicopters to check the settings and help you with the first flight.

Notes on trimming: see pages 12 + 30

### At take-off !

Prior to take-off the helicopter should be standing as level as possible. If you have to hold the helicopter inverted or at a steep angle before flying, switch the *HeliCommand* off, then on again before take-off. (When angled in this way, the gravitational forces are applied perpendicular to the rotor shaft which do not occur in normal flight, and these can have an adverse effect on the operation of the sensors.)

### Checking the controls before each flight

Check the controls and the neutral position of the swashplate, and repeat the check with stabilisation switched on. Do not take off before the servos are responding to the commands!

### Internal-combustion helicopters: vibration test !

Severe vibration or body resonance can cause serious problems with the correct operation of the sensor; three checks are therefore necessary:

- 1) Feel weather the case of the *HeliCommand* unit is vibrating.
- 2) Before take-off, switch to "yellow" mode and observe whether the swashplate stays level at all rotational speeds.
- 3) Take off initially in "OFF" mode, then switch stabilisation only briefly on and off again, as a first try for safety's sake. If applicable, repeat this at different motor speeds.  
If problems occur, please refer to the installation notes on page 16.

### Gain setting !

Start the test-flying schedule with a reduced gain setting for tail gyro and stabilisation and best to set up via the supplied channels! Depending on the type of helicopter and installed height of the unit, 100% or even only 65% may be allowed in Hor- and Pos-mode. Using higher gain, severe oscillatory movements may occur. This applies in particular when the distance between the sensor and the ground is very small (< 0.5 m).

Set the gain so that optimum stabilisation is achieved in the "green" Pos mode at an altitude of about 0.5 m.

If oscillation occurs → reduce. If drifting uncontrolled → increase.

With tail rotor gyros it is usual practice to set the gain hard up against the limit of oscillation, but this is not necessary with the Pilot channel of the *HeliCommand*. "Softer" settings look better in flight, as the model's flight path is affected less directly by the *HeliCommand*'s spontaneous control actions.

If your helicopter is extremely unresponsive or extremely agile, you may find it necessary to optimise the stabilising effect by making use of the supplementary settings which are available via the PC adaptor.



During high-speed flight the *HeliCommand* only brakes the model slowly by itself. This means: if you override the *HeliCommand* by giving powerful control commands (see page 34), you will have to control the helicopter actively. Please note that a variable "forward freewheel" option can be set using the PC adaptor.

## 30-31

### Trimming

If the automatic trim is not used, then it is better to set the trims initially with the stabilisation switched off.

After this, and always when the transmitter trim positions have been changed significantly, the transmitter neutral setting should be re-calibrated using the SET button (see page 22).

In the first few seconds after take-off, the accuracy of the stabilisation system is reduced, but precision automatically increases after about ten seconds of flying.

For this reason, when the Hor- or Pos-mode is active, it is good to wait a little while, rather than setting the trim immediately. In most cases the trim does not need to be readjusted after this.

If the trim is different with and without stabilisation: the transmitter neutral setting needs to be re-calibrated (page 22).

### Tail rotor trim (internal gyro)

The transmitter trim slider is only used once, to adjust it to the neutral point of the internal gyro (even when using auto trim). This can be done with the model on ground: While in heading hold mode, trim the transmitter so that the tail servo, which can remain in various positions, stays in the centre without drifting off by itself. (This tail trim is not affected by the SET button; SET only calibrates roll and elevator).

If during flight the tail responds un-equal at both directions, the best way is to adjust the centre correctly: Trim with heading hold OFF. Then you can see the tail rotor in its correct position. Note this position, neutralize the trim (or the autotrim, resp.) and re-adjust mechanically into the noted position.

Generally we recommend to set the internal REVO mixer (via PC adaptor), this enhances the stability to a large extent.

*Note: some common tail gyros automatically adapt their neutral point to the presently received trim position, each time they are switched on. The HeliCommand intentionally does not do this; only the sensor-null is re-calibrated each time. (The neutral point is fixed on 1.52 ms). Therefore, the stick position during switch-on is arbitrary; but it is necessary once (for the first flight) to trim manually. Only in case of rapid temperature change, small trim adjust-ment may be necessary - or the HeliCommand can be forced to readjust itself by switching off and on again.*

### With automatic trim

Simply press the auto-trim button on the transmitter, regardless of the stabilisation mode you are using. The helicopter only needs to have been in an approximately steady flight state for about eight seconds before you do this. The trim always refers to the transmitter's neutral setting, as calibrated in the *HeliCommand* unit. For this reason it is not possible to adjust the aileron and elevator trim on the transmitter at the same time (in fact, you can tape over the trim sliders!). However, if you do move them, the new values must be "learned" again as the "transmitter neutral setting" (page 22) before you use the auto-trim button on the transmitter again.



## Tips for flying

### Take-off and landing

You can switch the stabilisation on before take-off or during the flight.

**Important:** never set the gain higher than the optimum value established during the test-flying schedule.

### Hovering

The effect of position mode is strongest when the helicopter is flying close to the ground. At the other extreme, the *HeliCommand* gives you more latitude for free movement at greater altitudes.

If you are a beginner, start by flying at a height of around 0.5 - 1.5 m; in any case this is the easiest altitude at which to learn. If you fly higher and get into difficulties, the safest direction of escape is upwards. Position mode is effective up to a height of around 3 metres in flat calm conditions; up to about 1 m if windy. Horizontal mode is effective in any condition.

The stabilising effect only works properly when the helicopter is flying.

When the machine is standing on the ground with the rotor spinning, it must be controlled manually!

### Control travels

The *HeliCommand* can be overridden manually even when gain is set to maximum; it is overridden if you move the aileron or elevator transmitter controls past about 50%. (When you neutralise the aileron and elevator controls, the *HeliCommand* becomes active again immediately.) If you are a beginner we therefore recommend that you control your model with small stick deflections, and set Expo at the transmitter!



If you reduce travel at the transmitter (Dual Rates), this might disable the manual override facility. For safety reasons you must however retain a means of overriding the system, and this can be achieved by reducing the pilot channel at the same time. If your transmitter features multiple flight modes (phases), you can pre-set the pilot channel to different values using flight mode programming. If you wish to reduce control travel permanently, we recommend that you carry out the changes on the *HeliCommand* using the PC adaptor.

During high-speed flight, the *HeliCommand* will only brake the model slowly by itself. This means: if you override the *HeliCommand* by giving powerful control commands, you will have to control the helicopter actively in order to slow it down, i.e. you should not carry out such manoeuvres unless you are confident of the control commands required.

### Effect of the opto-sensor

Position mode works entirely without a visible horizon; that is why it also operates properly close to trees etc.

If you are a beginner to helicopters it is best to restrict your flying to normal ground surfaces (grass, gravel etc.) This should ensure that maximum stabilising effect is always available.

### In darkness, or when overflying optically smooth surfaces

(water, snow, car roofs, smooth unpatterned indoor floors etc.)

In such cases, i.e. when the optical ground sensor cannot detect sufficient contrast, only horizontal mode will be active even when the unit is set to "green" (position) mode. Brief contrast interruptions are bridged by the intelligent software, and will not be noticed by the pilot. However, if the contrast remains too low for a long period, the remaining instruments automatically take the stabilising role; if this should happen, you will need to keep an eye on the helicopter's position and, if necessary, correct it with slight stick deflections.

If you have to fly under the conditions stated above, for safety's sake you should select "yellow" horizontal mode beforehand. If you are unsure, check the contrast as described below.

### Indoor flying

Use "yellow" mode. "Green" mode is taboo unless you check the floor contrast from different distances (see below) and limit yourself to normal flight attitude (in "green" position mode don't fly inverted indoors - even with the *HeliCommand 3D*!).

### Checking the contrast

In the "green" position mode the LED will flicker to warn you that the contrast or brightness is not sufficient; this means that the *HeliCommand* has automatically switched to "yellow" horizontal mode. You can check this close to the ground and at various distances above ground.

Also, the sensor's response can be watched, by setting "green" position mode and moving your hand under the *HeliCommand* at a distance of about 30 cm.

## Versions and applications

### *HeliCommand 3A*

This basic Version is not suitable for aerobatics and 3D manoeuvres (no inverted flight is allowed, or the unit would have to be re-powered before using the stabilisation again).

The *HeliCommand 3D* and *RIGID* are designed specifically for this type of flying!

### *HeliCommand 3D* and above

For brief 3D flying (inverted flight or single turn-around manoeuvres) the "yellow" horizontal mode can be left switched on to provide support. This mode provides stabilisation in normal flight and inverted flight. You can still override the stabilisation manually. The degree of manual control can be varied using the pilot channel, and a wide range of additional adjustment facilities is available using the PC adaptor.

One particular use is for switching between positive and negative hovering. The stabilisation can also be switched on for use as an "emergency knob", but please note the following points in this regard:

### 3D manoeuvres

For agile 3D manoeuvres with a multitude of subsequently flown rolls, loopings etc, even the *HeliCommand 3D* should be switched to OFF (red) beforehand, and not switched on again until at least 15 - 20 seconds after the manoeuvring has finished.

The same applies to multiple stall-turns, since these may affect the horizontal neutral detection under certain circumstances.

### *HeliCommand RIGID*

Activating *RIGID* mode using the PC adaptor minimises the effects of wind gusts and ballooning when flying into wind or in high speed.

In this mode unrestricted 3D flying and aerobatics are possible, and can be carried out with excellent accuracy.

When you switch on horizontal or position stabilisation, the same applies as stated for the *HeliCommand 3D*; see above.

## Notes

- Over tall grass, loose foliage etc. it is always better in the interests of safety to fly fairly high, because objects moving about in the rotor downdraught may adversely affect position mode, or switch to the horizontal "yellow" mode.
- If the model is subject to a rapid change in temperature, please wait for at least five minutes for the system to settle down before you switch on, and do not use the system below -5°C or above +50°C. (If the stabilisation is switched off, it can be used between -10°C and +50°C.) It is best to switch on only just before take-off, and then to leave the helicopter level, i.e. avoid touching it in any way.
- If drift is detectable after a 90° ... 180° tail rotor rotation, the installed attitude in the model can be optimized (see fault-finding).
- Don't use the system in the rain - short circuit hazard!

### For skilful pilots: differences in handling

- Switch off the stabilisation before flying stall-turns, because - of course - the system would try to return the helicopter to the horizontal attitude.
- Use "green" position mode only for hovering and for slow flying close to the ground!
- To incline the helicopter at large angles, e.g. in order to brake from high speed, you will need to apply larger control deflections than without stabilisation. For auto-rotation: reduce the gain.
- To fly smooth turns hold the nominal angle of bank with aileron, otherwise the helicopter will try to right itself.

### Range of applications

The system is designed to make it easier to control model helicopters as used by hobby pilots.

Caution! Not designed for manned vehicles or for military purposes. Infringement is strictly prohibited; breaches of this rule will be pursued as a licence violation.

The modelling versions *HeliCommand 3A*, *3D* and *RIGID* are not suitable for use in built-up areas, close to or above buildings and installations.

For professional applications such as still photography / filming / surveying etc. the *HeliCommand Profi* should always be used. See on page 13.

## Safety measures

The terms "auto-pilot" or „stabiliser“ do not mean that the model flies completely automatically!

As with any conventional model helicopter flying, great care and practice are required when using this product.

No auto-pilot is capable of eliminating the dangers of operational errors.

It could even be argued that the risks are greater with such an aid, because the ease of control could allow a pilot to become careless, or sway less trained pilots into flying in situations where they cannot regain control if a technical fault should occur.

Technical instruments are liable to failure, and a helicopter fitted with more instruments incorporates more items which could go wrong.

As everyone knows, flight instruments are not immune to problems and failure. In the interests of safety, no pilot should ever rely exclusively on the stabilisation system, and pilots should satisfy all required safety measures at all times.

## We recommend

- Always keep your model a safe distance from persons and objects, and fly in a cautious, conscientious manner.
- Do not under-estimate the energy contained in spinning rotor blades. For practice-flying with larger model helicopters we recommend that you fly behind a safety net or football goal, as are present at many model flying sites.
- If you are a beginner, ask a model pilot with experience of helicopters to help and advise you - especially when test-flying a new model or a first installation of the *HeliCommand*.
- Set the stabilisation level to suit the ambient conditions. Always operate the *HeliCommand* in such a way that you can switch it to manual control in flight, or at least in such a way that you can override it in an emergency.
- Always fly at approved model flying sites, well away from residential areas and public roads, and observe legal requirements.
- Keep well clear of radar stations, radio transmitter masts and other potential sources of radio interference.
- Third-party insurance is in most places a basic essential when flying model aircraft.
- Never take your eyes off the helicopter when it is flying.
- If you ever pass on this product, be sure to pass on these warning notes to the new owner.

## Liability exclusion

Specialised knowledge and expertise are required in order to install, set up and operate the *HeliCommand* and the helicopter itself. Errors and negligence can result in accidents, which may cause serious personal injury, damage to property or traffic accidents. Since the manufacturer and retailer are unable to ensure that you handle the product correctly and competently, we can do no more than expressly point out these hazards. We deny liability for any damage resulting from the use of our products, from problems in the installed instruments and from failure of the signal transmission link, unless such denial contravenes statutory requirements.

## Guarantee

We guarantee this device for a period of 24 months. The till receipt given to you when you purchased the product serves as proof of the start and finish of the guarantee period. Any repairs carried out under guarantee do not extend the guarantee period. During the guarantee period we will correct any functional defects, material faults or production faults at no cost to you. We will not consider additional claims, e.g. for consequent damage. Goods must be sent to us pre-paid; we will pay return carriage. We will not accept packages sent without pre-paid postage. We accept no liability for transport damage or the loss of your shipment; we recommend that you take out suitable insurance to cover this risk.

The following requirements must be fulfilled if your guarantee claim is to be processed:

- You must send the till receipt to us together with the product.
- You must have operated the unit in accordance with the operating instructions.
- You must have used only recommended power sources and genuine accessories.
- There must be no damage present caused by damp, unauthorised intervention, excess voltage, overload or mechanical stress.
- Please include a brief but accurate description of the fault, to help us locate the problem.

## Fault-finding

Servos do not move → see page 8 „LED indicators“

Digital servos show a slight noise → no problem, see the FAQ on the Website

### Jitter or oscillation in position mode, especially when close to the ground

- Reduce gain of position mode (on PILOT channel or better via PC on „Position sens.gain“)
- Installed position too low?  
→ Install as high as possible, see page 17
- Try increase PC-setting of aileron & elevator travel.
- For some slow reacting models, or in rigid mode, it might be necessary to increase setting of „Horizontal sens.gain“ (via PC).

### Machine is not stable in position mode, especially at higher altitude

- Sensor window dirty?  
→ Protect from exhaust (glow models), clean regularly
- Low-contrast ground surface, e.g. snow, smooth asphalt, water?  
→ Switch to horizontal mode
- Trim not "learned" correctly? see page 30
- Increase gain further? → via Pilot channel or PC
- Dense clouds of exhaust gas in the vision beam?  
→ Set motor leaner, and install unit further away from the exhaust.
- Aerial wire or other obstacles in the sensor view beam?  
(see first paragraph on page 17, "Installation")
- Much loose foliage or tall grass etc., moving in the rotor draught?  
→ Switch to horizontal mode.

### Flight attitude not steady, in position and in horizontal mode

- Vibration (visible or invisible), or excessive body resonance affecting the case (especially with glow motors)?  
→ See page 13 > Internal-combustion engines.
- Original double-sided foam tape not used and/or not horizontally arranged?  
→ See page 16

### Trim discrepancies with and without stabilisation

- After take-off the accuracy of stabilisation increases automatically within a few seconds of flying.
- Transmitter trims moved? → Calibrate ("learn") the neutral setting again.
- Severe temperature fluctuations?  
→ Leave the unit for about five minutes to acclimatise, then switch on again.
- Severe vibration? → See "Flight attitude not steady" fault

### Automatic trim not working accurately

- Have you moved the transmitter trims?  
→ See page 30. Either re-calibrate the trim or avoid touching the transmitter trims.
- Pitch-minimum correctly calibrated (SET-button)? → without given pitch, the auto trim is disabled
- Internal tail gyro has not been trimmed for? (→ page 30)

### Drift after tail rotor swing

- Unit not installed exactly vertical; lightweight helicopter with high blade pitch angle?  
→ Optimise by flying a 90° right-hand turn from the hover, with stabilisation set to "yellow" mode. If the helicopter was stationary before the quarter-pirouette, but always drifts in a particular direction afterwards, then the installed location can be optimised.  
If the model drifts at an angle left / forward (relative to the new position), incline the *HeliCommand* further to the left; the reverse applies if it drifts right / rearward.  
If the machine drifts right / forward, tilt the *HeliCommand* slightly forward; do the reverse if it drifts left / rearward.

### Inverted flight:

- Roll centre deviation when hovering inverted, or after switching back  
→ Optimise the setting „neutral tilt compensation“ (PC setup software).

### Drift after aerobatic manoeuvres (stall-turns, rolls etc.)

- *HeliCommand 3A* in use?  
→ Not suitable for inverted flight or steep flight attitudes!  
→ upgrade to **3D**.
- External tail rotor gyro in use, and rotational (yaw) rate > 400° / second?  
→ Reduce rotational rate (Seite 25)
- Completed a series of full rotations, such as multiple stall-turns, rolls or loops?  
→ See notes on page 34!

**Specification**

Operating voltage: 4,8 ... 6 Volt (4 ... 5 NiXx)  
Current drain: 55mA (at 5V)  
Dimensions: 55 x 35 x 22,5 mm  
Weight incl. cables: 33g  
Temperature range: -5° ... +50°C; +23° ... +122°F  
in „OFF“ mode: -10° ... + 50° C; +14° ... +122°F

Swashplate linkage types: CCPM (separate servo functions, H1, single servo)  
ECCPM:  
Tri-Link H3(120°), H3(140°), H3(90°), Four-Link H4(90°), H4(90+45°)

Max. allowed turn rates in „hor“- and „pos“-mode:  
aileron and elevator: ≤ 200 °/s  
yaw (also if external gyro used) : ≤ 400°/s  
In EXTREM mode (HeliCommand Rigid only): unlimited turn rates!

Compatible with all current analog and digital servos, except for „narrow-pulse“ (760 µs) servos.

Compatible with all usual RC systems, as for example:  
Robbe-Futaba PPM / PCM 1024 / PCM G3 modulation / 2,4 GHz  
Graupner/JR PPM 8, PPM 12, SPCM modulation  
MPX PPM8, PPM 12 with UNI modulation  
Any other transmitters with standard 1.5 ms neutral position.

**Set contents**

- HeliCommand main unit
- RC module (with cable distributor)
- Mounting bracket
- Self-adhesive double-sided foam tape, 2 sets of 2 strips each
- Cable ties
- Instruction manual

**Accessories**

- PC adaptor with software CD  
- for serial COM-port (RS 232)  
- for USB-port a USB-to-serial adaptor is needed
- Spare RC module set (for use in additional models):  
(for HeliCommand with 4-pin socket)  
(for HeliCommand with 3-pin socket)  
- containing micro controller  
- incl. mounting bracket, hook-and-loop tape, cable ties and foam tape to change HeliCommand main unit
- Version update and upgrade: CAPTRON Electronic GmbH

**Service**

CAPTRON Electronic GmbH  
Johann-G.-Gutenberg-Str. 7  
82140 Olching  
Fon +49 8142 4488 -0  
Fax +49 8142 4488 -100

**Imprint**

CAPTRON Electronic GmbH  
Johann-G.-Gutenberg-Str. 7  
82140 Olching

Internet: [www.helicommand.com](http://www.helicommand.com)  
E-Mail: [info@helicommand.com](mailto:info@helicommand.com)  
Fon +49 8142 4488 -0  
Fax +49 8142 4488 -100

Notes:

---

---

---

---

---

---

---

---

---

---

---

---

---

---

---

---

---

---

---

---

---

---

---

---

---

---

**HeliCommand Profi**

Autopilot for remote controlled helicopters

- Increased precision and reliability when used with industrial helicopters
- Commercial applications such as filming, aerial photography, surveying, monitoring
- Reduction of crash risk
- Ideal training aid
- Additional support for long-range flying

WORLD NOVELTY

[www.helicommand.com](http://www.helicommand.com)

